

Hallco



Hallco Portable Hand Sanitiser

HSS1

INSTALLATION AND USER MANUAL



R H Hall, Hallco House, Beacon Court, Pitstone Green Business Park, Pitstone, LU7 9GY
T: 01296 663400 F: 01296 663401 E: sales@rhhall.com W: ww.rhhall.com

Index

P1	Introduction, Warranty Information and Included Contents
P2	Dimensions, Specification and Product Features
P3	Installation and Safety Details
P4	Commissioning
P5	Emptying/Refilling and Cleaning
P6	Spare Parts and Contact Information

Introduction

Thank you for your purchase of the HALLCO HSS1 Hand Sanitiser Station. This manual provides instruction for safe and proper use of the item.

Warranty

The HSS1 Hand Sanitiser Station is sold with a 12 months warranty from date of purchase from R H Hall or from one of its approved dealers. The warranty is limited to the replacement of faulty parts or products and excludes any consequential loss or expense incurred by the purchaser. Defects which arise from faulty installation, inadequate maintenance, incorrect use or fair wear and tear are not covered by the warranty.

The warranty applies to goods installed within the United Kingdom only.

For Warranty Calls, please contact your Approved Dealer or the R H Hall Customer Service Team

01296 663400 – customerservice@rhhall.com

Delivery

The packaged unit contains:

Hallco Hand Sanitising Station: Fully Assembled Hand Sanitising Station	1
Instruction Booklet	1
Key	1

Please note this unit is not supplied with Sanitiser Liquid.

Please notify R H Hall or your approved dealer on the day of receipt if anything is missing or damaged.

01296 663400 or sales@rhhall.com

Check that the correct machine has been supplied. The data plate is located on the rear of the unit.

Dimensions, Specification and Product Features

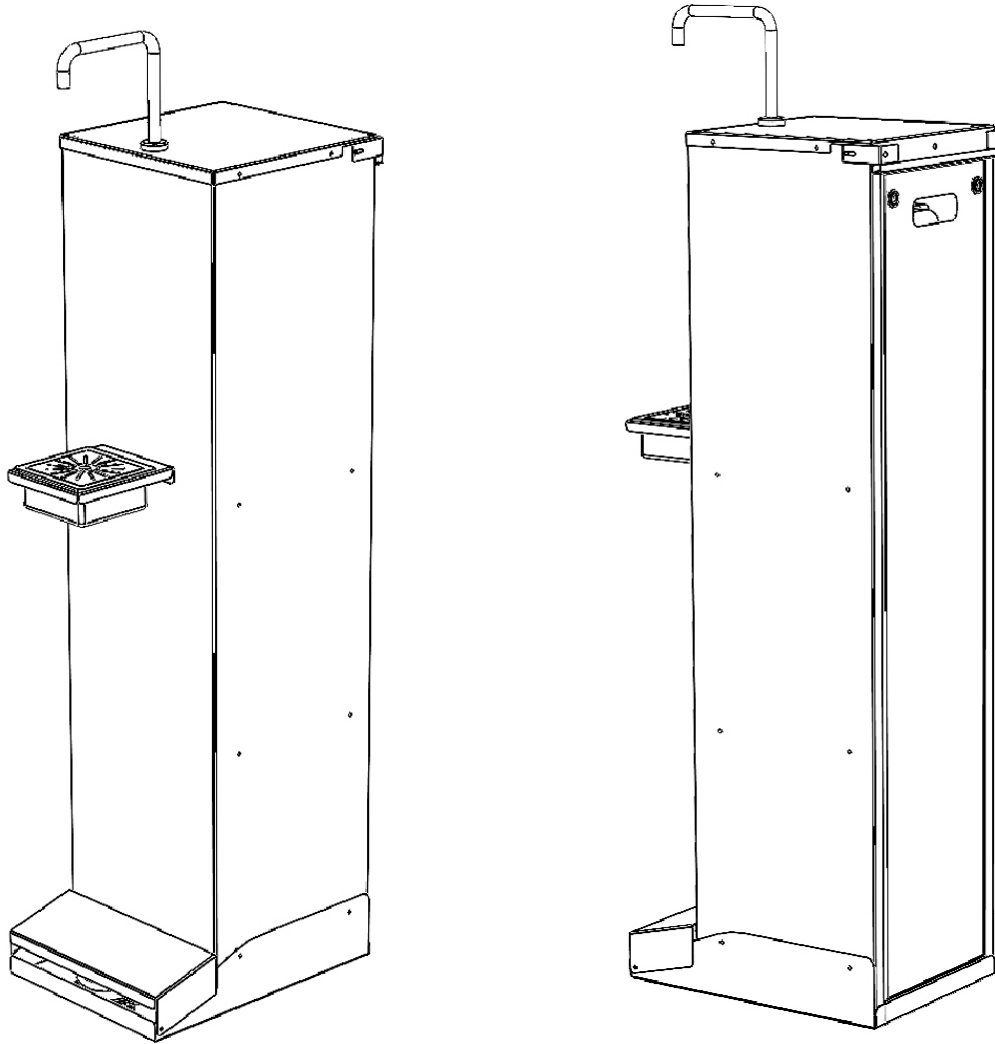

Overall External Dimensions (mm)	260 W 410 D 1140 H (to top of highest spout position)
Capacity	3 x 5 Litres
Net Weight	12kg
Electrical Requirement	None

PRODUCT FEATURES

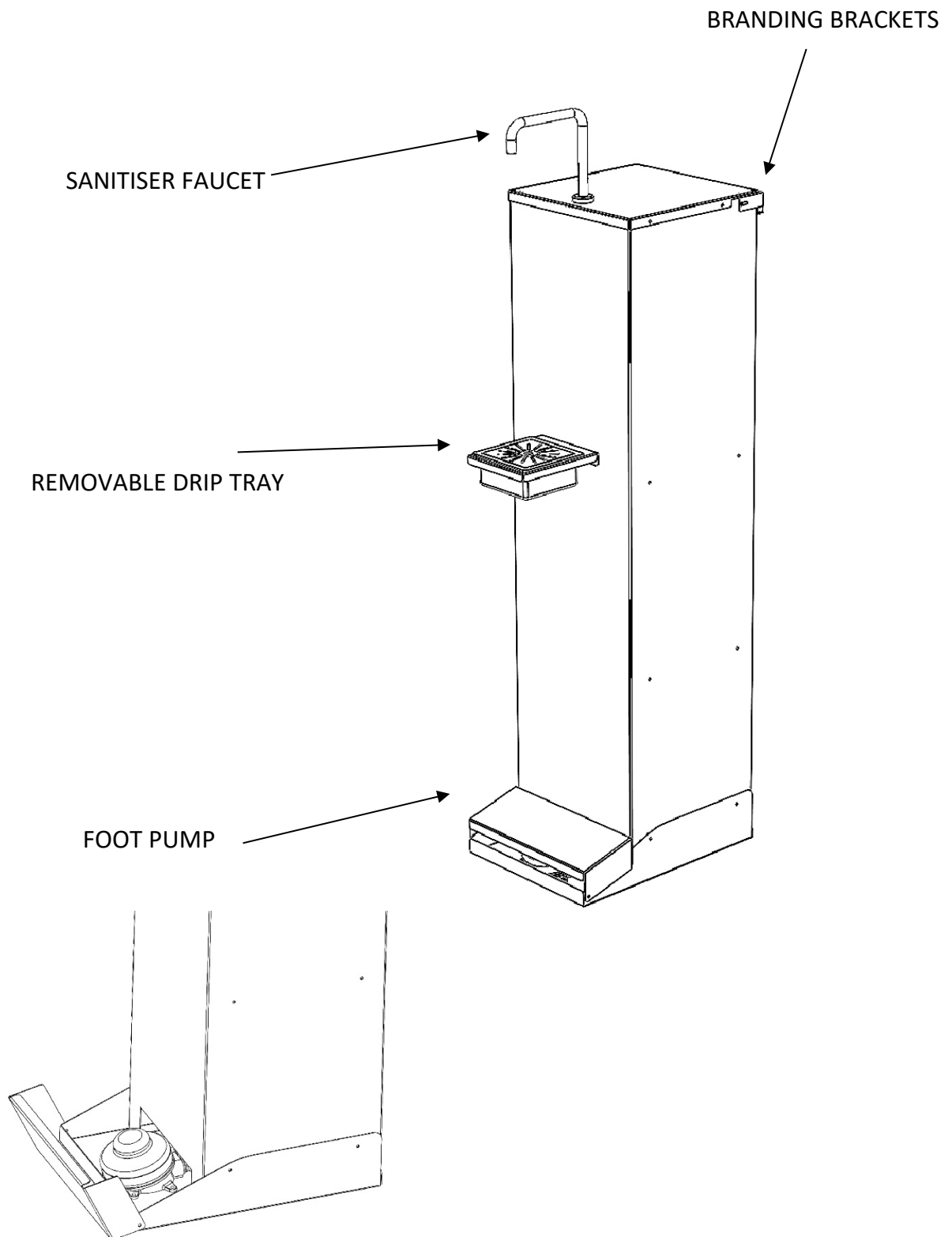

Installation

These instructions contain important information designed to help the user obtain the maximum benefit from their investment.

Please read them carefully before starting work and consult with your distributor/supplier in the event of any queries.

Be sure to leave this Instruction Manual with the user after installation of the machine is complete, or in a safe location.

Procedure



WARNING

The following table shows the weight and the minimum quantity of people required to lift the unit:

	Net Weight	Quantity of People
HSS1	12kg	1

Before use; remove all packaging and ensure that the unit is checked over for damage, any damage must be reported to the carrier or distributor/supplier immediately.

Location

The Hand Sanitising Station is only suitable for use where there is no risk for the unit to be adversely affected by its surrounding environment.

The unit must be stationed on a flat surface capable of safely supporting the unit's weight when fully laden with sanitiser.

The unit comes with 4 pre-assigned holes if you wish to fix the unit to the floor. Please note you will need to leave enough space behind the unit to empty and refill.

Commissioning

To first use, unlock the rear door using the 6.5mm key. One lock is located on the left and one on the right. Pull the door towards you and up to remove the door.

Once the rear panel has been removed, Place a 5 Litre container onto each shelf (x3 containers in total) and remove the lid of the top bottle. Place the tube into the top bottle, ensuring it isn't touching the bottom of the container. *Note the suction tube is only suitable for 5 litre containers.*

The rear panel can now be refitted. (Note there are two security locks on the back panel which can be used to secure the back panel and the unit if being left unattended). Use the key provided and secure the door in place using the two locks.

Hinge the foot cover at the front (hinges towards you) and pump the foot pump until the sanitiser flows freely. Close the foot cover onto the pump and activate the pump by pressing down on the centre of the foot pedal.

Your sanitiser unit is now ready for operation.

***NOTE: This unit can only be used with Liquid Sanitiser (Do not use Gel Sanitiser)
We recommend Chemex ABC Hand Rub – Product Code 1405.
Please ask our team for details or to re-order.***

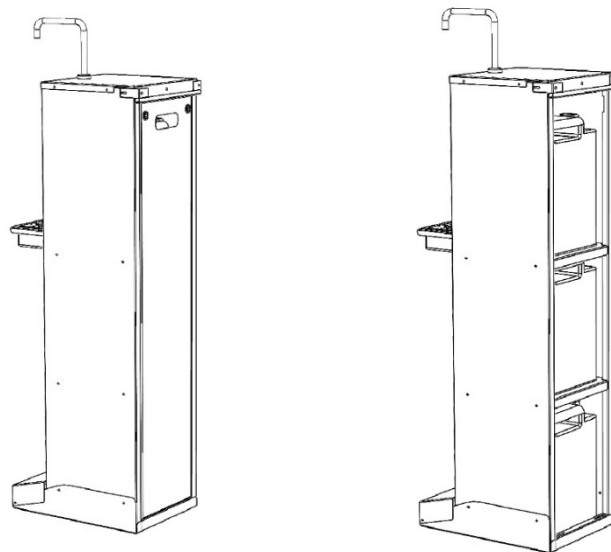

Note the pump cover is required to restrict the volume of sanitiser dispensed per operation. This should only be opened to prime the unit with sanitiser.

The spout can be lowered and/or raised depending on its position if required.

The drip tray is removable.

To adjust the branding brackets please use a screwdriver and loosen the screws on the side. Place the branding panel into the U channel (ensuring branding panel is not thicker than 10mm) and push the two clamps tight to the branding before tightening the screws with a screwdriver.

Emptying / Refilling

Once the unit has completed its total number of operations, the sanitiser liquid container will need replacing. To replace the sanitiser liquid container, follow the steps outlined in the commissioning section. Always ensure the sanitiser in use is located on the top shelf.

Cleaning

Clean the external areas of the unit as required; using a damp cloth and an appropriate cleaning product.

This product is covered in an antibacterial coating. Please ask a member of our team for more details if required.

DO NOT USE CLEANING MATERIALS CONTAINING ABRASIVES OR BLEACHES.

SPARE PARTS

Ordering Spare Parts

In the event that spare parts or accessories need to be ordered, please always quote the serial number located inside the rear door of the machine. Please provide this information to your Approved Dealer or the R H Hall Spares Team

01296 663400 – spares@rhhall.com

For further information on please call R H Hall on 01296 663400 Alternatively, contact us via email:

R H Hall Sales Team – sales@rhhall.com

R H Hall Customer Service Team – customerservice@rhhall.com

R H Hall Spares Team – spares@rhhall.com

We hope you are completely satisfied with your purchase!